



**AC002 European Standard**  
Column Double Gun Charging Pile  
Installation Manual

# AC002 European Standard

## Column Double Gun Charging Pile

### Installation Manual



## **Legal Statement**

---

This document is an integral part of the technical documentation "Charging infrastructure" and is protected by copyright. Any use outside the strict limits of copyright law without written consent is prohibited. This also applies to copies, translations, photographed versions of documents, and documents stored and processed on electronic media.

Any party that violates this provision is obliged to compensate for the loss!

## **Disclaimer Guarantee and Limitation of Liability**

---

- All information, specifications and illustrations in this manual are based on the latest information available at the time of printing, and images and illustrations depicted in the manual repertoire may differ slightly from the actual.
- The Company reserves the right to make changes at any time without notice. Although this manual has been carefully checked, it does not guarantee the completeness and accuracy of the contents of the manual, including but not limited to product specifications, features, illustrations, etc.
- Before operating or maintaining this machine, please read this manual carefully and pay special attention to the safety warnings and precautions.

## CONTENTS

1.General Outline .....	6
1.1 Purpose .....	6
1.2 Application Scope .....	6
1.3 Warning Symbol Definition .....	6
1.4 Safety Precautions .....	7
2. Preparation before installation .....	10
2.1 Installation site .....	10
2.2 General construction tools .....	11
2.3 Construction materials .....	12
2.4 Installer requirements .....	13
2.5 Construction drawing confirmation .....	14
2.6 Equipment spacing requirements .....	14
2.7 Power cable recommendations .....	16
2.8 Current & distribution capacity requirements .....	17
2.9 Requirements for cement foundation (Column mounted) .....	19
2.10 Grounding/insulation resistance requirements .....	20
3. Installation Steps .....	20
3.1 Unpacking and unpacking inspection .....	20
3.2 Equipment installation .....	23
4. Post-Installation Inspection .....	28
4.1 Installation and wiring inspection .....	28
4.2 Inspection before power on .....	28
4.3 Power on .....	29
5.Platform Settings .....	31
5.0 Display Introduction .....	31
5.1 Default Setting .....	31
5.2 Charging Process .....	33

6. Emergency Operation .....	38
6.1 Emergency stop function .....	38
6.2 Emergency stop button position .....	38
6.3 Reset .....	39
7. Completion Information .....	39
Appendix 1 .....	40
Appendix 2 .....	41
Appendix 3 .....	42

# 1. General Outline

## 1.1 Purpose

This document is intended to guide construction personnel through the field installation of AC002 AC chargers.

## 1.2 Application Scope







### 1.2.1 Applicable equipment type

AC002 AC chargers.

### 1.2.2 Applicable people

AC002 AC charger installer.

## 1.3 Warning Symbol Definition

Serial Number	Symbol	Implication
1		Indicates that extreme caution must be exercised or a situation involving hazardous voltage.
2		This is important safety information and must be handled with extreme caution or in situations.
3		Indicates a burn hazard arising from hot areas or areas with high component temperatures.
4		Protective earth connection
5		AC electricity
6		Indicates that the said action must be performed using clothing and/or personal protective equipment provided by the employer.

## 1.4 Safety Precautions

Before starting operation, please read the operating instructions and precautions carefully to reduce the occurrence of accidents. The "Caution, Caution, Warning, Danger" items in the product and product manuals do not represent all the safety items to be observed, but are intended to supplement the various operational safety precautions.

When performing various operations of our products and equipment, we must comply with the safety codes of the relevant industries and strictly observe the relevant equipment precautions and special safety instructions provided by our company.



Please keep this manual properly.

### Security instructions


The internal working voltage of the charging system is high and the current is large. In order to ensure personal safety, the following regulations should be observed at all times:

1. Only personnel who have received training and sufficient knowledge of charging systems may install charging systems. During installation, always follow the safety precautions at the end of the catalog and local safety regulations.
2. To work inside the charging system, make sure the charging system is not live. The mains input of the charging system must be disconnected.
3. Power distribution cables should be properly routed and protected to avoid accidental contact when operating power supply equipment.
4. It is strictly forbidden to wear a watch on the wrist.
5. When water or moisture is found in the fuselage, please turn off the power immediately. When operating in a humid environment, strictly prevent moisture from entering the device.


### High voltage




When the power supply system is running, some components have high voltage, direct contact or indirect contact with these components through non-insulating objects will bring fatal danger.

	<p>Construction operations on high-voltage lines may cause fire or electric shock accidents. AC cables must be erected and routed in accordance with the local regulations and specifications. Only personnel qualified for high-voltage and alternating current operations can perform various high-voltage operations.</p>
---	--

### Tools


	<p>When performing various operations of high voltage and AC power, special tools must be used.</p>
---	---

### Thunderstorm


	<p>It is strictly prohibited to use high voltage and AC power in thunderstorms.</p>
---	---


In a thunderstorm, strong electromagnetic fields are generated in the atmosphere. Therefore, in order to avoid lightning damage to equipment, good grounding of equipment should be done in time.


### Static electricity



	<p>Static electricity generated by the human body can damage electrostatic sensitive components on the circuit board, such as large-scale integrated circuits (IC), etc.. In contact with the equipment, hand holding the plug board, circuit boards, IC chips, etc., in order to prevent human electrostatic damage to sensitive components, you must wear an anti-static hand ring, and the other end of the anti-static hand ring well grounded.</p>
---	---

### Short circuit

	<p>It is strictly forbidden to short-circuit the non-grounding pole to ground during operation. A short circuit will cause equipment burnout and personal safety hazards.</p>
---	---


 The polarity of cables and interface terminals must be strictly checked when conducting live operations.

 The power distribution operation space is compact, so please pay attention to select the operation space before any operation.


-  Operation must use insulated tools.
-  When operating with electricity, you must pay attention to keeping your hands, wrists, and arms in a tense state, so as to prevent accidents caused by too much movement of the tool or human body when the tool slips.

## Others


### Sharp corners of objects







	When carrying equipment by hand, protective gloves should be worn to prevent being cut by sharp objects.
---	--








### Power cable

	Before connecting the cables, verify that the cable labels are correct.
---	---

### Signal Cable

	The signal cable should be tied separately from the power cable, and the spacing between the ties should be at least 15mm.
--	--

	Do not install or use this product near flammable, explosive, coarse or combustible materials, chemicals or vapors.
	Before installing or cleaning this product, please turn off the power.
	Do not use the device in areas where children are present.
	Please use this product in accordance with the specified operating parameters.
	Do not spray water or other liquids directly on the wall-mounted case. Do not spray water or immerse the charging gun in liquid. Please put the rechargeable gun into the protective holder to avoid accidents.
	If this product is cracked, worn, broken or otherwise damaged, or does not work properly, stop using it.

	If the flexible power cord or EV cable is worn, broken or otherwise damaged or does not work properly, discontinue use.
	Do not attempt to disassemble, repair, tamper with or modify this product. This product is not user-repairable equipment. For repair or modification, please contact your dealer.
	Please use caution when transporting this product. To prevent damage to the connector or its components, do not expose the connector to force or impact, do not pull, twist, tangle, drag, or step on.
	Do not touch the end of this product with your fingers or sharp metal objects (such as wires, tools or needles).
	Do not insert fingers or foreign objects into any part of this product.
	Do not fold or press any part of the product or damage the product with sharp objects. Do not fold or press any part of this product, or damage this product with sharp objects.
	Special tools must be used when performing various operations under high-voltage, AC power conditions.

## 2. Preparation before installation

### 2.1 Installation site

The environmental conditions listed in the table below need to be considered when selecting charging equipment.








Environmental conditions	Recommended range
Ambient temperature	-25°C ~ + 50°C
Altitude	<2000m
Humidity	5%~95%RH, no condensation inside the product;
Dustiness	≤1mg/m <sup>3</sup>

Corrosive substances	No pollutants, such as salt, acid, smoke, etc.
Vibration	≤1.5mm/s
Insects, pests, vermin beasts,	None
Mildew	None

### Sheet 2 Installation environment confirmation

- Do not install in areas prone to water immersion
- Please avoid the place where cars collide to install

## 2.2 General construction tools

Serial Number	Type	Name	Application	Picture
1	Wire preparation tools	Electrician's knife	Stripping of insulation sheath	
2	Installation tools	Wire stripping pliers	Stripping of the insulation layer	
3	Installation tools	Crimping pliers	Terminal crimping	
4	Installation tools	Impact Drill	Component card installation	
5	Installation tools	Electric wind-axe machine	Slotting	
6	Installation tools	Cutting machine	Tube cutting	
7	Installation tools	Hot air gun	Heat shrinkage of insulating material	

8	Installation Tools	Hot melt machine	Welding PE water pipe	
9	Installation tools	Allen wrench (full set)	Installation and removal of screws	
10	Installation Tools	Open-end wrenches (full set with No.13)	Installation and removal of nuts	
11	Installation tools	Angle grinder	Grinding of materials	
12	Installation Tools	Phillips screwdriver (full set)	Removal and installation of screws	
13	Measuring Instruments	Laser level	Level measurement	
14	Measuring Instruments	Leveling tape	Level measurement	
15	Measuring Instruments	Multimeter	Measurement of voltage, current, etc.	
16	Measuring instruments	Megohmmeter	Measurement of insulation resistance	
17	Auxiliary apparatus	Insulation floor mat	Placement of disassembled parts	
18	Lifting tools	Manual crane	Lifting of equipment	

### Sheet 3 General construction tools

Note: The above tools need to be selected according to the actual situation on site.

## 2.3 Construction materials

### 2.3.1 Cable wires

Refer to the following table, according to the different wire diameter, choose the corresponding terminal block.

Wire diameter	Terminal model
11AWG (4.17mm <sup>2</sup> )	RV5.5-6
8AWG (8.37mm <sup>2</sup> )	SC10-6
7AWG (10.55mm <sup>2</sup> )	SC16-6
6AWG (13.3mm <sup>2</sup> )	SC16-6/SC25-8
4AWG (21.15mm <sup>2</sup> )	SC25-6/SC25-8
3AWG (26.67mm <sup>2</sup> )	SC35-8

**Sheet 4 Cable diameter cross reference terminal table**

### 2.3.2 Network cable

For Ethernet communication, it is recommended to use Super Category 6 shielded twisted pair cable (cat6a) and RJ45 crystal head. The length of network cable should not exceed 75m, more than 75m, the customer needs to customize the construction plan according to the site conditions.

### 2.3.3 Other material

Auxiliary materials such as heat-shrinkable tubes and insulating tapes required for making cables.

## 2.4 Installer requirements

(1) Entering the construction site should comply with the construction site safety management regulations.

(2) Entering the construction site, you must correctly wear a helmet (tie the jaw belt, helmet intact), do not wear wide clothing, slippers and other unsafe attire, alcohol is strictly prohibited to work, smoking in the construction site is strictly prohibited.

(3) If the site is dusty or spray paint work, you must wear a protective mask.

(4) Try to stay away from various machinery and equipment, electrical lines to prevent mechanical and electrical injuries.

(5) Users of mobile power tools must master their use of skills and precautions, to try to wear insulated shoes, with insulated gloves, metal outer

(6) The site temporary electricity, the electrical box to keep intact, damage to the electrical components must be replaced in a timely manner.

(7) Do not plug the wire directly into the socket.

(8) Try to avoid working with electricity.

(9) When entering the pit, roof and other sides or various holes, you should concentrate on preventing falling from high places.

(10) Pay attention to the condition of the ground environment such as iron nails and steel bars to prevent other injuries such as sticking, touching, hanging and falling.

(11) Site construction protection facilities, safety signs, warning signs, etc. can not be removed without authorization.

(12) Construction equipment to strengthen the maintenance of the site, to keep intact.

## **2.5 Construction drawing confirmation**

When the installers arrive at the site, they first check the drawings of the installation location of the equipment and check to make sure that the cables of each equipment meet the requirements.

## **2.6 Equipment spacing requirements**

To ensure safe and reliable operation of equipment, ventilation and maintenance requirements, sufficient installation space and installation height should be reserved.

### **2.6.1 Installation space requirements**

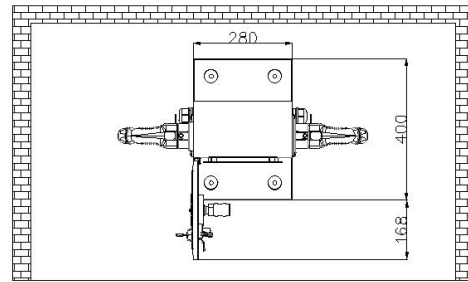
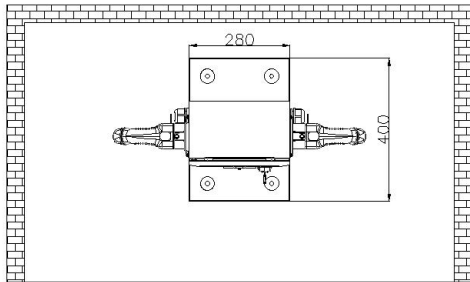
Dimensions(Width\*Depth\*Height): 386mm\*280 mm\*1630 mm

Space requirements as follows:

- The front side of the reserved distance  $\geq 400\text{mm}$  (to ensure the normal opening and closing of the front door and the smooth operation)
- The left side of the reserved distance  $\geq 200\text{mm}$  (to ensure that the gun seat inserted into the gun smoothly)
- The right side of the reserved distance  $\geq 200\text{mm}$  (to ensure that the gun seat inserted into the gun smoothly)
- The rear side of the reserved distance  $\geq 100\text{mm}$

### 2.6.2 Installation distance requirements

When the back or side of the charging pile to be installed is near the wall or other obstacles, a certain maintenance distance should be set aside. The installation distance of the base and the maintenance distance of the door should be shown in Figure 1 and Figure 2.

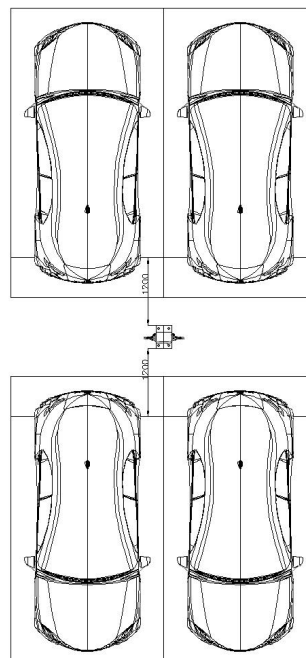


**Figure 1 Installation distance diagram**

**Figure 2 Maintenance distance diagram**

### 2.6.3 Car parking distance requirement

When the charging pile is installed in the middle of one parking space or back-to-back parking space, it is recommended to leave a space of 1200mm between the wheel stop and the charging pile to facilitate the use of the charging pile, as shown in Figure 3:



**Figure 3 Car parking distance requirement**

## 2.7 Power cable recommendations

AC002 AC chargers are recommended to use cables with 400V or higher voltage rating, and the cables should have at least 90°C temperature resistance level. The installer should confirm whether shielding is required according to local laws or terms and conditions, and if shielding is available, both ends of the shield should be connected to the PE wire.

The power distribution input wire diameter of the charging pile is recommended to be no less than the following recommended values. If this wire diameter is not in accordance with laws and regulations, please refer to local laws and regulations requirements.

Phase sequence/color	L1 Brown	L2 Black	L3 Grey	N Blue	PE yellow-green	Noted
AC002T27T27 single-phase 64A	5AWG (16.77mm <sup>2</sup> )			5AWG (16.77mm <sup>2</sup> )	5AWG (16.77mm <sup>2</sup> )	EU
AC002T2S7T2S7 single-phase 64A	5AWG (16.77mm <sup>2</sup> )			5AWG (16.77mm <sup>2</sup> )	5AWG (16.77mm <sup>2</sup> )	EU
AC002T211T211 three-phase 32A	8AWG (8.37mm <sup>2</sup> )	8AWG (8.37mm <sup>2</sup> )	8AWG (8.37mm <sup>2</sup> )	8AWG (8.37mm <sup>2</sup> )	8AWG (8.37mm <sup>2</sup> )	EU
AC002T2S11T2S11 three-phase 32A	8AWG (8.37mm <sup>2</sup> )	8AWG (8.37mm <sup>2</sup> )	8AWG (8.37mm <sup>2</sup> )	8AWG (8.37mm <sup>2</sup> )	8AWG (8.37mm <sup>2</sup> )	EU
AC002T222T222 three-phase 4A	5AWG (16.77mm <sup>2</sup> )	5AWG (16.77mm <sup>2</sup> )	5AWG (16.77mm <sup>2</sup> )	5AWG (16.77mm <sup>2</sup> )	5AWG (16.77mm <sup>2</sup> )	EU
AC002T2S22T2S22 three-phase 64A	5AWG (16.77mm <sup>2</sup> )	5AWG (16.77mm <sup>2</sup> )	5AWG (16.77mm <sup>2</sup> )	5AWG (16.77mm <sup>2</sup> )	5AWG (16.77mm <sup>2</sup> )	EU

Sheet 5 Wire diameter selection table

## 2.8 Current & distribution capacity requirements

Please confirm the information requirements of the distribution network in accordance with the following table and select the circuit breaker according to the recommended selection requirements.

**Note:** When installing the charging pile, the charging pile power supply line should be equipped with an independent circuit breaker or leakage protection device, and B type leakage protection device is recommended.

Charger Specifications	Distribution Grid Voltage	Wiring Type	Grid capacity	Rated current	Circuit Breaker Selection	Noted
AC002T27T27 single-phase 64A	230VAC,50/60HZ	L+N+PE	≥17.5kVA	80A	Ue=230V,≥80A,Thermomagnetic, Icu≥Ics≥40kA,2P	EU
AC002T2S7T2S7 single-phase 64A	230VAC,50/60HZ	L+N+PE	≥17.5kVA	80A	Ue=230V,≥80A,Thermomagnetic, Icu≥Ics≥40kA,2P	EU
AC002T211T211 three-phase 32A	400VAC,50/60HZ	L1+L2+L3+N+PE	≥27.5kVA	40A	Ue=400V,≥40A,Thermomagnetic, Icu≥Ics≥40kA,4P	EU
AC002T2S11T2S11 three-phase 32A	400VAC,50/60HZ	L1+L2+L3+N+PE	≥27.5kVA	40A	Ue=400V,≥40A,Thermomagnetic, Icu≥Ics≥40kA,4P	EU

AC002T222T222 three-phase 4A	400VAC,50/60HZ	L1+L2+L3+N+PE	≥55kVA	80A	Ue=400V,≥80A,Thermomagnetic, Icu≥Ics≥80kA,4P	EU
AC002T2S22T2S22 three-phase 64A	400VAC,50/60HZ	L1+L2+L3+N+PE	≥55kVA	80A	Ue=400V,≥80A,Thermomagnetic, Icu≥Ics≥80kA,4P	EU

**Sheet 6 Distribution network requirements and circuit breaker selection**

## 2.9 Requirements for cement foundation (Column mounted)

Before installing the charging pile, the cement foundation should be poured, the size of the cement foundation should be greater than 500mm\*500mm\*200mm, and the depth of the foundation should be 300mm. The design of the cement foundation can be adjusted according to the user's requirements and the actual situation on the site. The cement base diagram is shown in Figure 4. The requirements for foundation inspection are as follows:

- (1) Pay attention to the correction level when the foundation is poured.
- (2) The foundation installation is higher than the ground level, and the necessary maintenance channels are reserved according to the specific space on site.
- (3) The foundation surface drain is slightly inclined to avoid water accumulation.
- (4) The foundation is filled with C25 concrete.
- (5) On the basis of reserved cable holes, as shown in Figure 4.
- (6) Test the flatness with a level after the foundation is completed.
- (7) Fix the holes reserved for four M10 expansion screws. See Figure 4 for hole spacing.
- (8) Reserve one cable hole. The cable hole is calculated according to the actual cable situation on site.

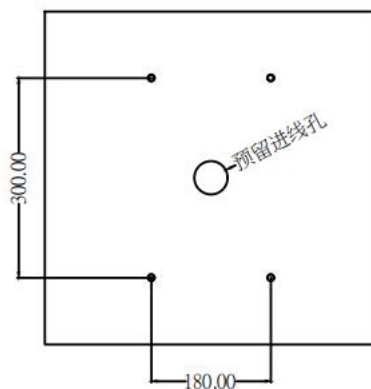



Figure 4 Schematic diagram of cement base of charging pile

## 2.10 Grounding/insulation resistance requirements

- (1) Check the civil grounding resistance test report to ensure that the resistance value of the grounding network made on site needs to be  $\leq 4\Omega$ .
- (2) Check the civil insulation resistance test report to ensure that the cable insulation resistance resistance value  $\geq 10M\Omega$ .

 Noted The above requirements are the minimum requirements for this equipment, and the specific standards are subject to local laws and regulations.

## 3. Installation Steps

### 3.1 Unpacking and unpacking inspection

#### 3.1.1 Equipment packing list

Name	Packaging	Configuration	Random documents	Accessory List
Equipment body	Cardboard box	Standard	<ul style="list-style-type: none"> <li>- Certificate of Conformity</li> <li>- Factory inspection report</li> <li>- Installation manual (electronic version)</li> </ul>	<ul style="list-style-type: none"> <li>- The key.</li> <li>- RFID card</li> <li>- Screws.</li> <li>- USB flash drive</li> <li>- Print wire</li> </ul>

Sheet 7 Equipment packing list

#### 3.1.2 Unpacking and inspection

- (1) Check the packing list number and equipment quantity.
- (2) Check the equipment nameplate information.
- (3) Check the completeness of the random documents.
- (4) Check whether the spare parts and accessories are complete.
- (5) Check the factory inspection report and certificate of conformity.

(6) Check whether the equipment appearance is good, whether there is deformation, bump, stain, etc.

### 3.1.3 Unpacking notes

(1) The installer shall unpack the equipment in the presence of the owner and fill in the unpacking record in detail.

(2) After unpacking and checking, the owner's representative should be asked to confirm the signature on the equipment unpacking record sheet.

(3) Equipment unpacking and acceptance process found problems, in addition to making records, waiting for the owner to negotiate with the supplier.

### 3.1.4 Product parts introduction

(1) The components of the product facade are shown in Figure 5

(2) The internal structure of the product is shown in Figure 6

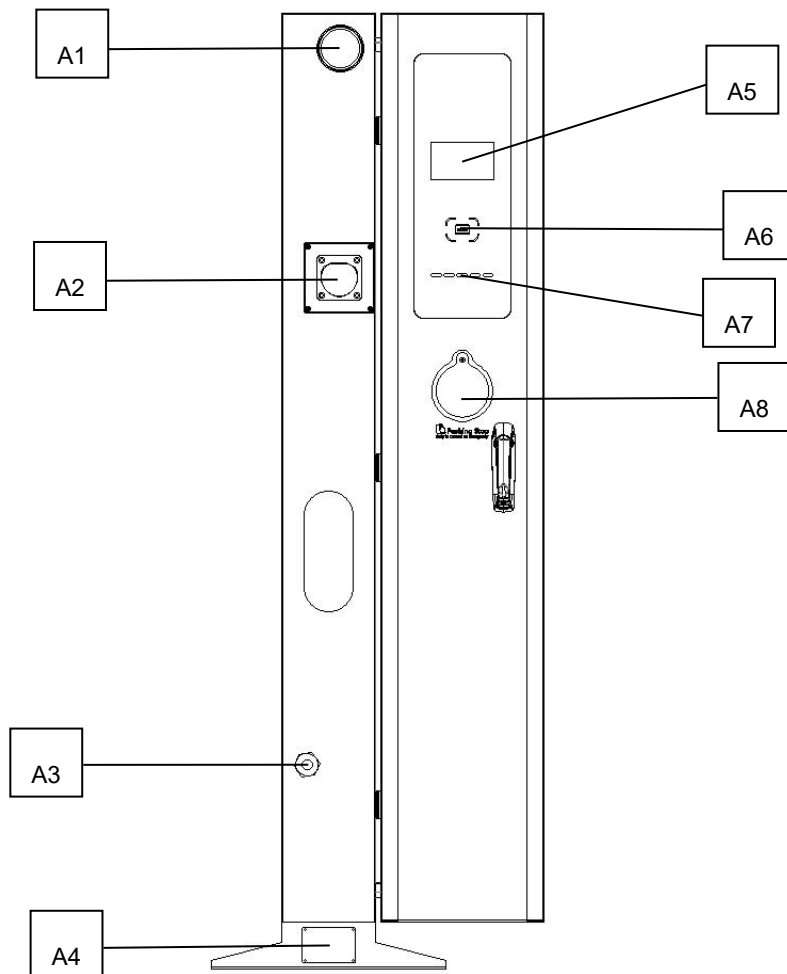
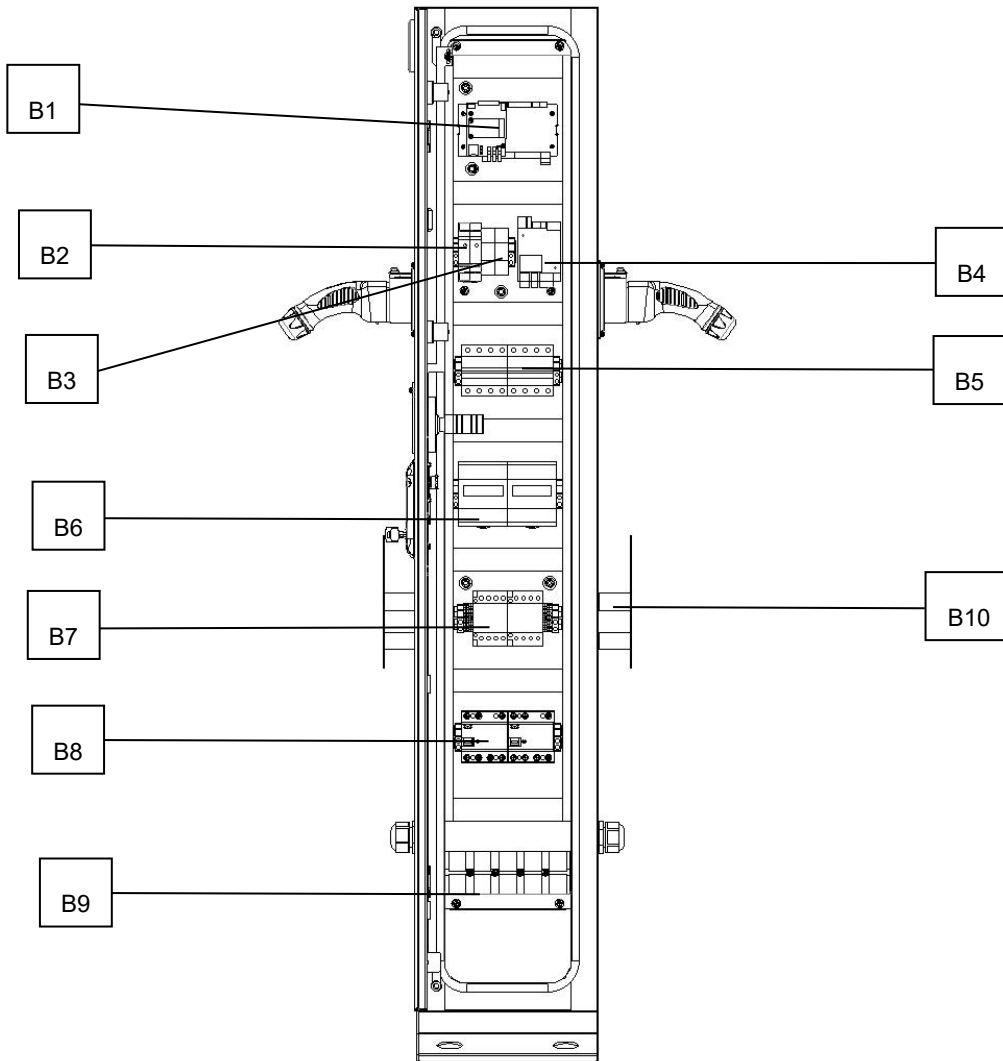


Figure 5 Facade component diagram

A1	Wire	A2	Gun holder	A3	AC gun cable outlet	A4	Nameplate
A5	Touch screen	A6	Card reader	A7	Indicator light	A8	Emergency stop switch

**Sheet 8 Description of facade components**



**Figure 6 Internals diagram**

B1	OCP control mainboard	B2	Auxiliary power supply	B3	Solid-state relay	B4	RCP mainboard
B5	leakage circuit breaker	B6	AC meter	B7	AC contactor	B8	Miniature circuit breaker
B9	Terminal block	B10	Wire hanger				

**Sheet 9 Description of Internals**

## 3.2 Equipment installation

### 3.2.1 Installation size

The installation dimensions of the equipment are 1630mm × 280mm × 386mm, and the external dimensions are shown in Figure 7.

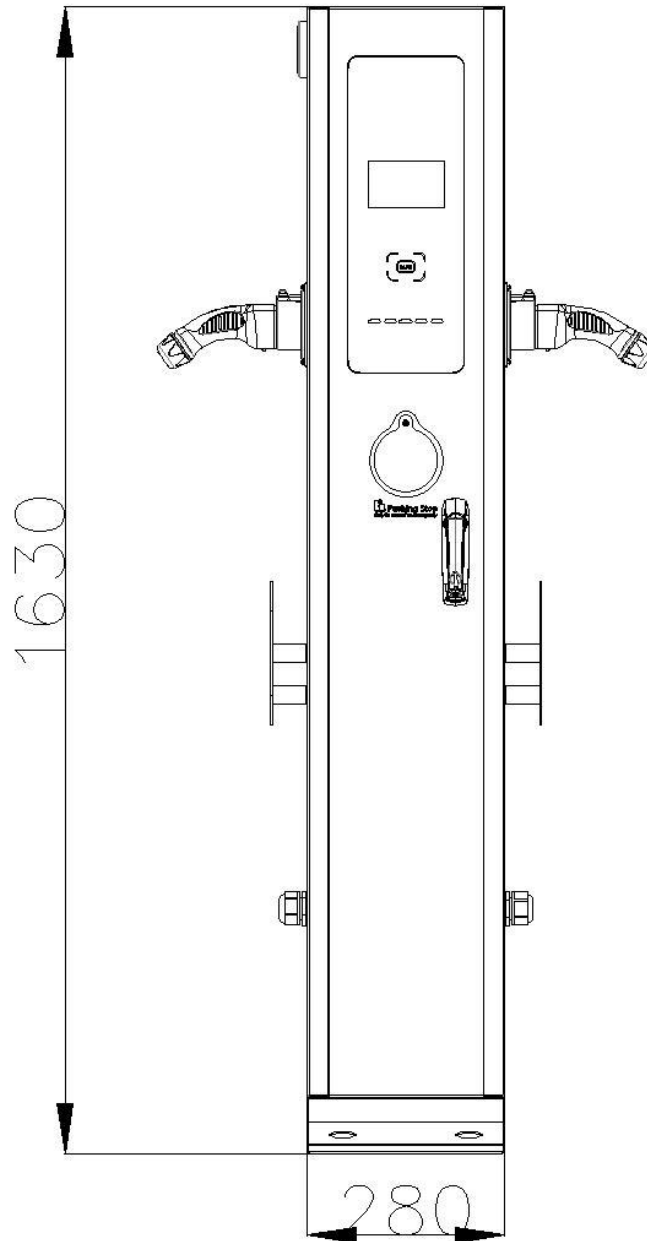


Figure 7 Schematic diagram of product size

### 3.2.2 Unpacking

Open the carton box.

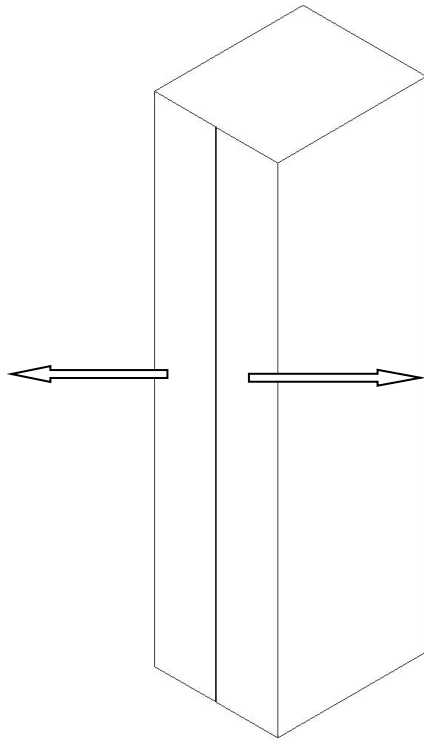


Figure 8 Schematic diagram of product unpacking

### 3.2.3 Transfer and installation

(1) After removing the nut spring flat washer, install four M10\*80mm expansion screws.

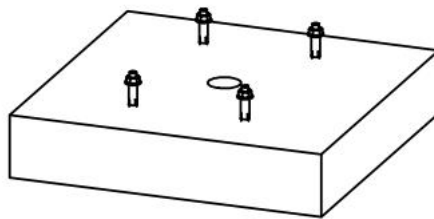
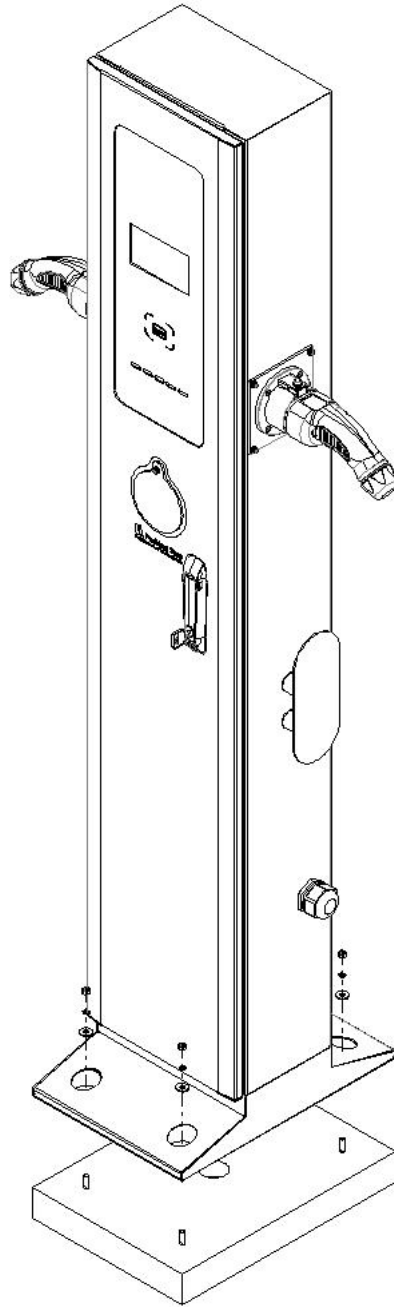


Figure 9 Installation diagram of expansion screws

(2) Align the cabinet with the expansion screws and lower it down



**Figure 9 Cabinet placement diagram**

Note: ① Lift or move equipment, must use special load-bearing forklift/crane, pallet truck or other professional load-bearing transfer device, and arrange professionals to operate

② Do not tip or strike the device

③ Move the equipment to the concrete foundation made in advance, and you can choose to use the hoisting method or the lifting forklift to carry the charging pile in place.

④ Ensure that cables are exposed inside the cabinet along the sealing sleeve, and ensure that the holes in the cabinet are aligned with the bolt holes.

(3) Insert through flat washers, spring gaskets and hex nuts at the four corners and in the middle of the front and back sides

(4) To lock these nuts, use a torque of 95.5N•m

Note: Keep the device upright and tilt Angle cannot exceed  $\pm 15^\circ$

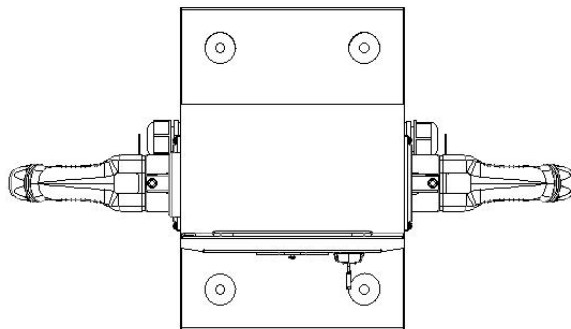


Figure 11 Top view after installation

### 3.2.4 Wiring

(1) Open the front door and confirm that the circuit breaker and leakage protection switch should be placed in the OFF position before wiring.

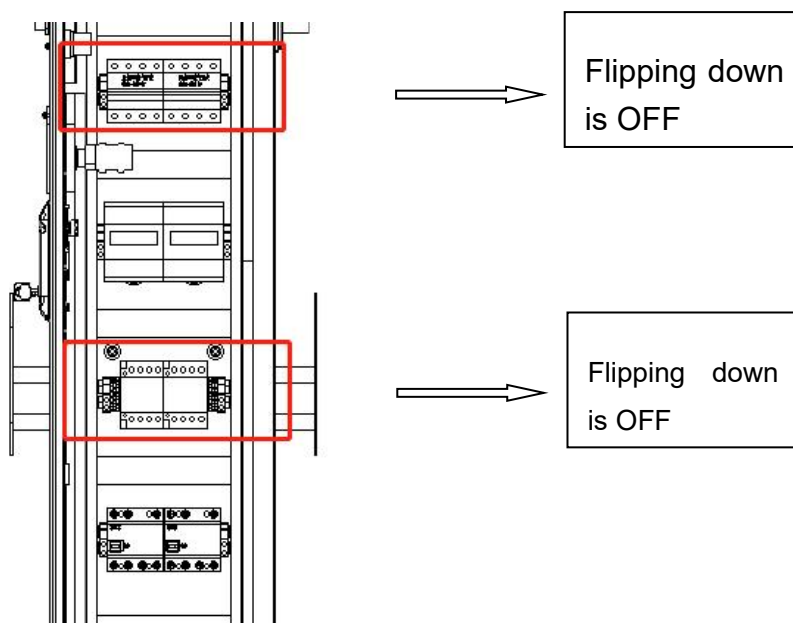
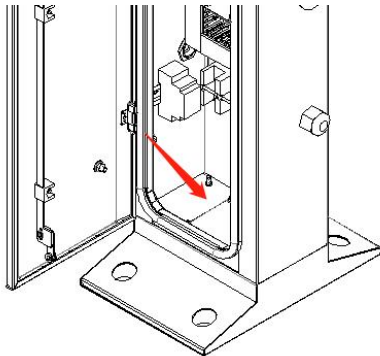
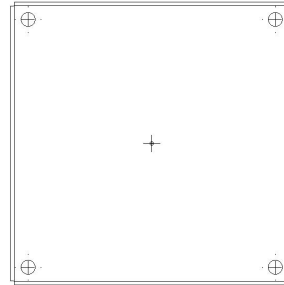


Figure 12 Circuit breaker diagram

(2) Remove the nut, take off the charging pile bottom cable installation plate, use a hole opener to open the hole, the size of the hole according to the size of the cable diameter.



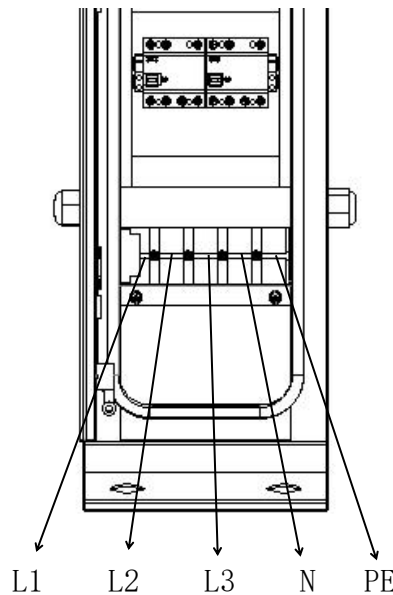
**Figure 13 Installation plate at the bottom of the charging pile**



**Figure 14 Schematic diagram of the installation plate**

(3) Connect the power wire

Select the power cable according to the requirements in Section 2.8. Find the wiring bar which is located at the bottom of the pile, and connect the wire according to Figure 15. At the same time, ensure that the cable is not broken, damaged, or scratched.



**Figure 15 Schematic diagram of wiring**



**Warning:**

**Must be performed in accordance with the specifications and the correct operating procedures. Incorrect implementation may lead to personal injury or death, etc.**

## **4. Post-Installation Inspection**

### **4.1 Installation and wiring inspection**

#### **4.1.1 Equipment and equipment fixation inspection**

(1) The appearance of the charging pile is neat and tidy, no bumping damage, and the position is in line with the hanging frame and fixed firmly without loosening.

(2) The orientation of the equipment meets the installation standards.

(3) There is no leakage of equipment installation accessories.

(4) Level meter measurement equipment book evaluation in line with the requirements.

#### **4.1.2 Cable laying and connection inspection**

(1) Check whether the cable insulation sheath is scratched and damaged.

(2) Check whether the power cable terminal is compliant and wired securely.

(3) Check that the communication cable terminals are correct and free from looseness.

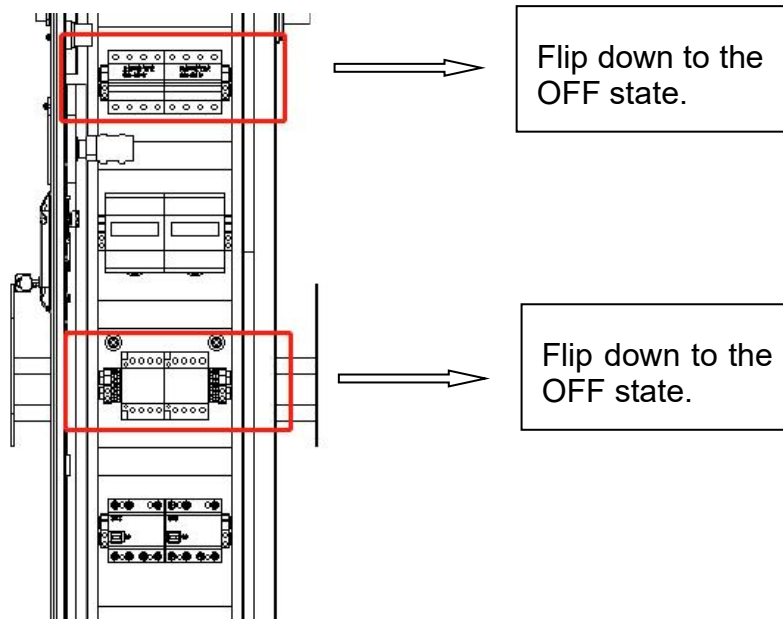
(4) Check whether there is a hanging cable label.

(5) Check whether the bending radius of the cable meets the requirements.

(6) Check whether the electrical grounding is reliable.

### **4.2 Inspection before power on**

Before powering on the device, check whether the power supply at the cable end of the empty entry of the MCCB in the low-voltage PDC is normal. There are no phase, overvoltage, undervoltage, and phase sequence abnormalities. The circuit breaker should be placed in the OFF position, as shown in the figure below.

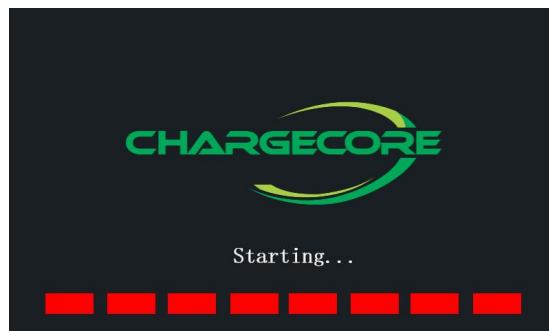


**Figure 16 Schematic diagram of circuit breaker**

After ensuring the above operations such as stable charging post installation and reliable wire wiring, the charging post can be powered on.

### 4.3 Power on

- Turn on the main gate of the external power supply of the charging pile.
- Turn on the circuit breaker and leakage protection.
- Close the door.
- The startup screen is displayed. The green light is on. (Note: See the table below for details of the lamp board indicator)



**Figure 17 Screen displayed after power-on**

Specific description	Indicators				
	POWER	READY	CHARGE	FAULT	NETWORK
Charging pile is powered up but not connected online.	Green light	Green light	No lights	No lights	No lights
Charging pile is powered and networked (WIFI / 4G / Ethernet).	Green light	Green breathing light	No lights	No lights	Green light always on (After connect OCPP)
Charging pile is powered and networked (WIFI / 4G / Ethernet); Turn on the simulator S2 switch; Start charging in any way.	Green light always on	Green breathing light	Green light	No lights	Green light always on
Press the emergency stop button after charging.	Green light always on	Green breathing light	No lights	Red light	Green light always on

**Sheet 10 Comparison of charging pile status and indicators**

## 5.Platform Settings

### 5.0 Display Introduction

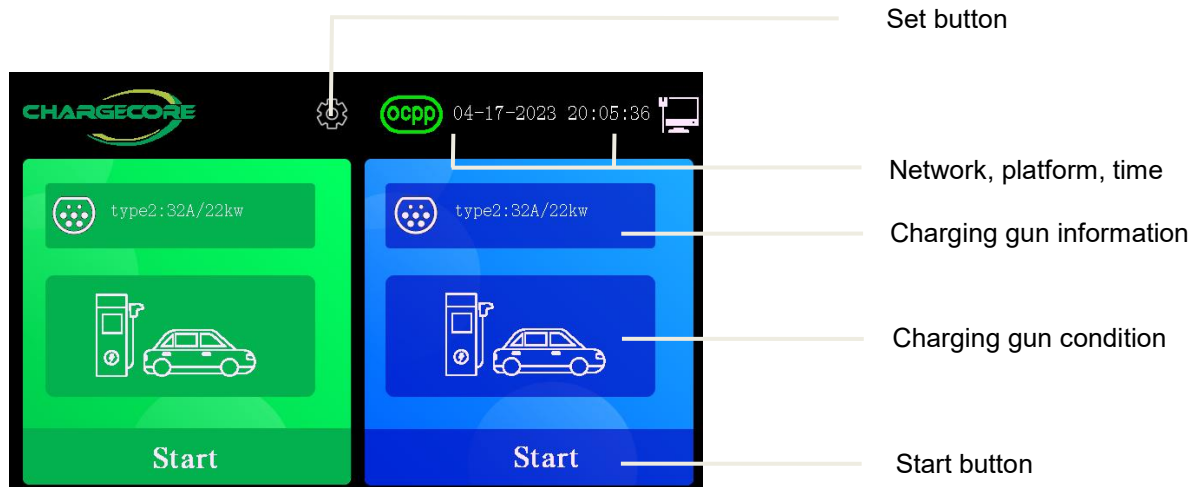


Figure 18 Home page introduction

### 5.1 Default Setting

#### 1.Admin Login



Figure 19 Home page "Settings"

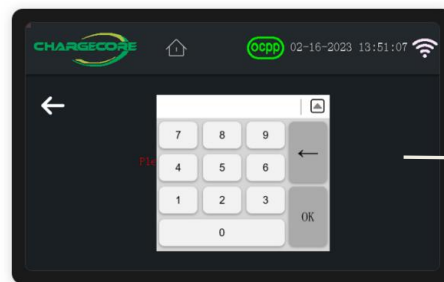


Figure 20 Password input

#### Description: How to change the password?

- Log in to the administrator interface, select "Basic Settings" and click the "Password" button.
- Enter the six-digit old password, new password, and confirm the new password (Figure 22), click "Confirm" and the modification is successful.

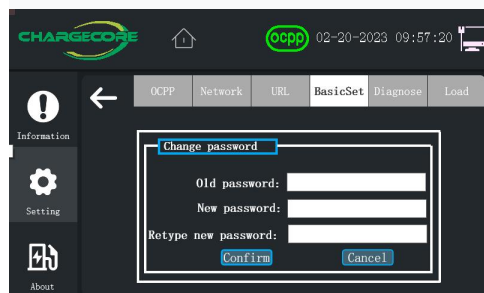


Figure 21. Basic Setting Diagram

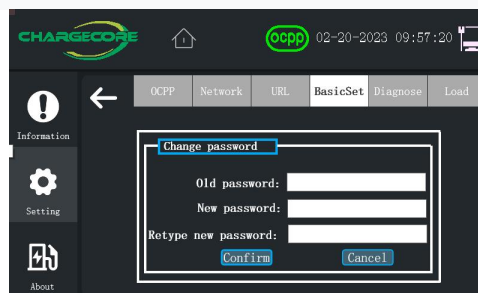


Figure 22. Change Password

## 2. Network Configuration

-After entering the management interface, select "Network".

-Support WIFI, 4G, Ethernet.

-The signal icon in the upper right corner of the screen is displayed as the corresponding networking mode (as shown in Figure ), that is, the network connection is successful.

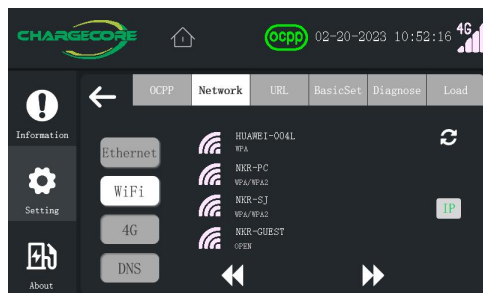


**Figure 23 Network configuration success signal icon**

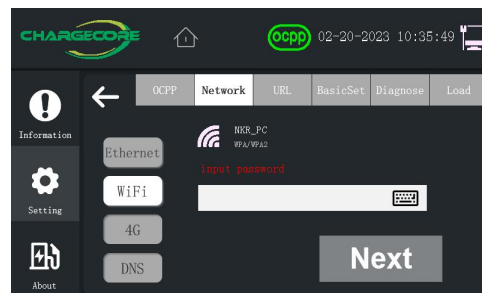
### ➤ Set up WIFI

Step1: Select WIFI > Click Refresh

Step2: Enter WIFI password > Next step to confirm



**Figure 24 Select WIFI**

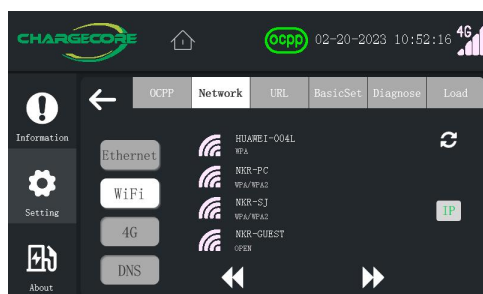


**Figure 25 Enter WIFI password**

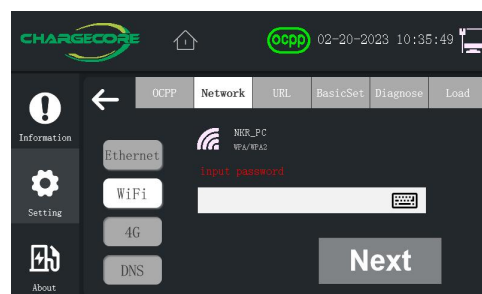
### ➤ Set up 4G

Step1: Select 4G > Set corresponding parameters

Step2: Confirm to switch to 4G



**Figure 26. Select 4G network**



**Figure 27. Confirm switch network**

## ➤ Set up Ethernet

Select Ethernet > Tick Obtain Automatically/Set IP Address Manually > Confirm Connection

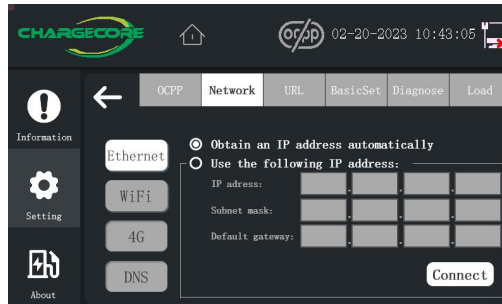


Figure 28 Select Ethernet

## 3.OCPP Platform Connection

After the charging pile network configuration is completed, it will automatically connect to the OCPP platform within 60s. After the connection is successful, the OCPP icon on the screen will light up (as shown in Figure 29 )



Figure 29 OCPP connection into

## 5.2 Charging Process

1. Take out the plug gun, insert the charging gun into the charging port of the vehicle, and the screen icon changes at this time (as shown in Figure 30 and Figure 31)

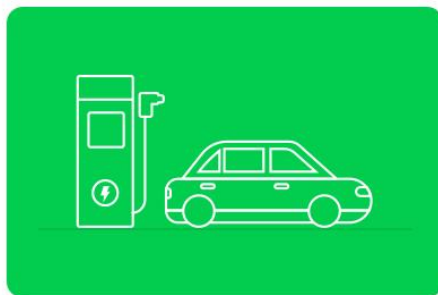


Figure 30 Unplugged state

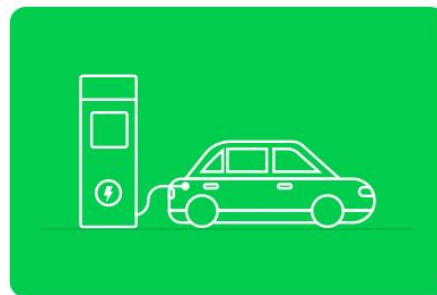
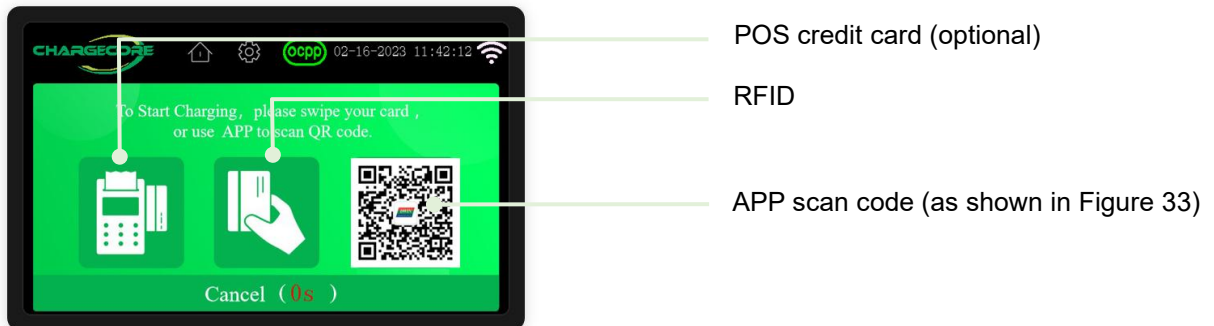



Figure 31 The gun is not inserted

2. After inserting the gun, click the "start" button and select the payment method.

- Support RFID activation, APP scanning code activation, POS credit card activation (optional)



**Figure 32 Payment method selection**

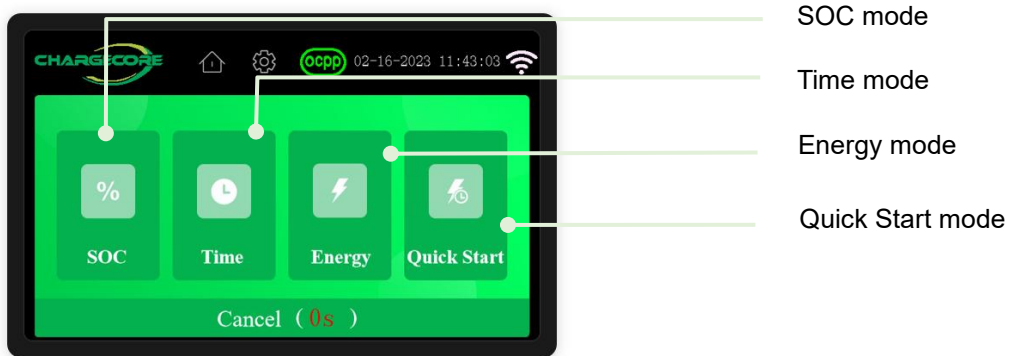
\* App home page click “” button to scan the QR code (Note: For details on how to use other functions of the APP, please refer to the APP instruction manual)



**Figure 33 Chargecore interface**

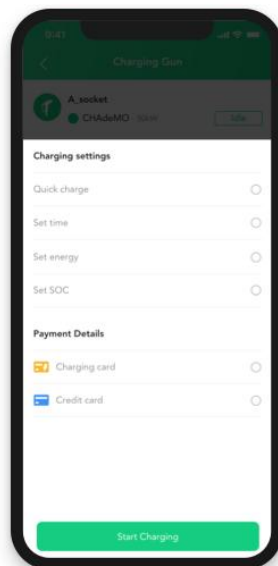
### 3. Select charging mode

- Support SOC mode, time mode, power mode, fast charging mode.



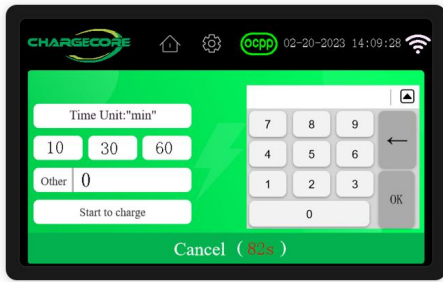
**Figure 34 Charging mode selection-screen operation interface**

\* After the app scans the QR code, it enters the charging mode and payment method selection (note: please refer to the app instruction for detailed app usage)

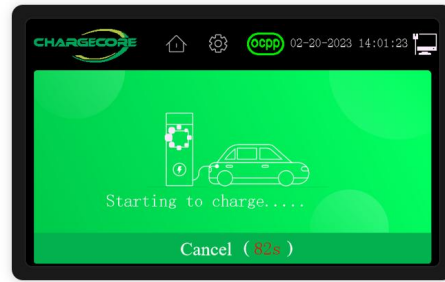


**Figure 35 Charging mode selection-App operation interface**

- Click to select SOC mode/time mode/power mode
  - a. Enter the percentage of power required for this vehicle (%) / the required charging time for this time (min) / the required power for this charging (kwh) (as shown in Figure 36).
  - b. Click to start charging.



**Figure 36 Time mode**



**Figure 37 Initiating charging**

- Click to select the fast charging mode to start charging immediately.

#### 4. Charging

- View vehicle charging details in real time (as shown in Figure 38)
- Charging will end automatically after it is fully charged / click the "STOP" button to end charging in advance

(Note: When using the App to charge, you need to operate the "STOP" button on the App)



- The vehicle has reached the battery level this time
- The vehicle has been charged this time (KWh)
- The charging time of the vehicle (h/min/s)
- Voltage (V)
- Current (A)
- Charging gun power (KW)

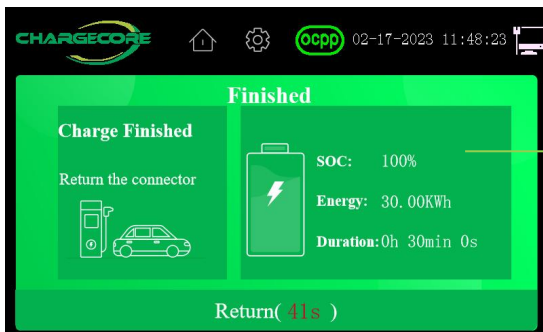
**Figure 38 Charging interface**

#### 5. Pay for the order and view the order details (as shown in Figure 40)

- When choosing an RFID card, you need to swipe the card again to pay (as shown in Figure 39).
- When choosing an app, the payment will be automatically completed in the credit card/debit card bound to the app in the app.
- No need to operate when selecting the POS machine, the payment will be completed automatically after the charging stops.



**Figure 39 RFID card settlement interface**



The vehicle has reached the battery level this time (%)

The current charge of the vehicle (KWH)

The charging time of the vehicle (h/min/s)

**Figure 40 Order details interface**

6. After charging, pull out the charging gun and put it back in place.

## 6. Emergency Operation

### 6.1 Emergency stop function

The emergency stop alarm is not part of the normal charging operation, only when there is an abnormality or misoperation, refer to this part. Do not use the "emergency stop button" for normal shutdown.

**Emergency stop:** Only in case of emergency, pressing the side "emergency stop button" system will cut off the output power. It can be reset by pressing the emergency stop button again.

### 6.2 Emergency stop button position

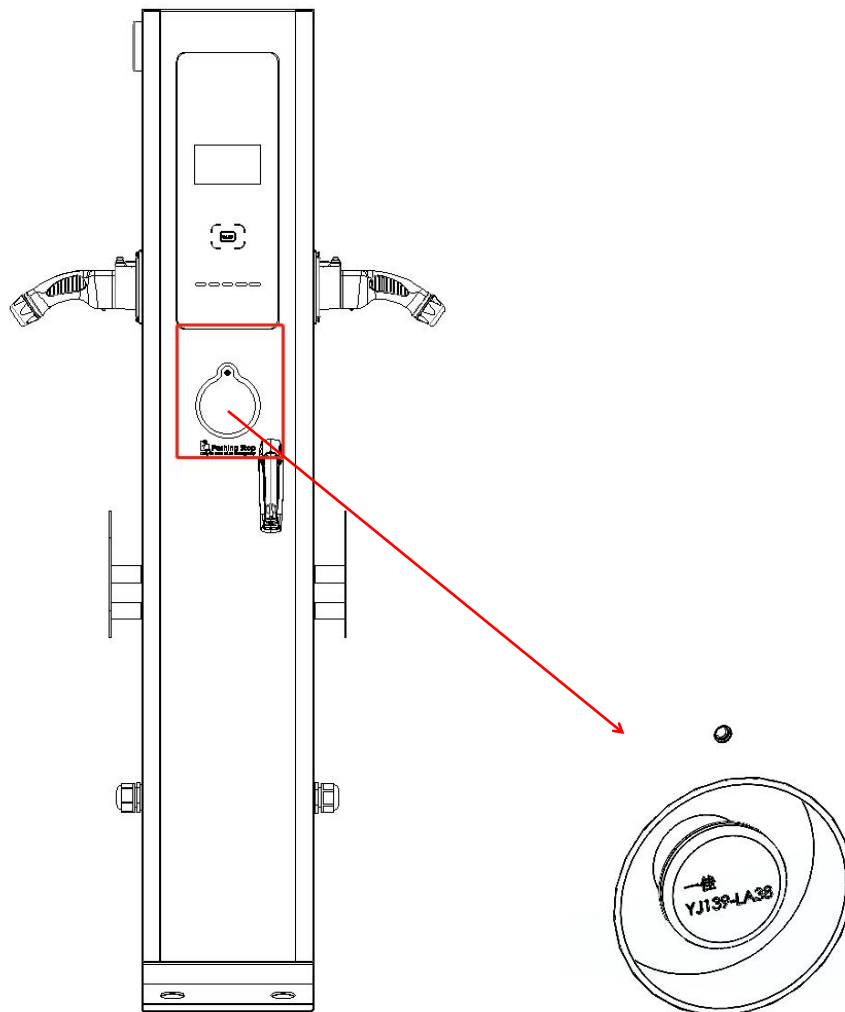


Figure 41 Emergency stop button

### 6.3 Reset

Turn the emergency stop button clockwise to reset.

## 7. Completion Information

Number	Documentation name	Page	Document necessity
1	Unpacking record sheet	1	√
2	Pre-Installation checklist	1	√

## Appendix 1

Unpacking record sheet						
Dealer name				Date		
No.	Item name	Goods	Quantity	Certificate number	Condition	Remark
1						
2						
3						
4						
5						
6						
7						
8						
9						
10						
Unpacking conclusion						
Signature column	Installation unit			Owner unit		

## Appendix 2

Pre-Installation Checklist				
Project name:				
Civil construction unit:			Equipment installation unit:	
Sub-project	No.	Main acceptance items	Acceptance record	Treatment measures
Installation plan	1	Whether the on-site equipment installation conforms to the construction plan design drawings.		
Distribution box circuit breaker	1	Meet equipment installation requirements (40A).		
Cable type	1	Refer to Sheet 5 in Chapter 2.8 to select the cable diameter and quantity according to the actual situation.		
	2	Network cable cat6a (for Ethernet communication).		
Wall mount foundation	1	Dimensions meet the requirements.		
	2	The foundation bolts meet the requirements of Chapter 2.10 in the installation manual.		
Maintenance access	1	The inspection channel meets the equipment spacing requirements in Chapter 2.7.		
In conclusion:				
Note: (1) Fill in "√" or "×" in the acceptance record according to the on-site situation; (2) Fill in "qualified" in the conclusion according to the on-site situation "needs rectification".				
			Signature: _____	
			Year    Month    Date	
			MMDDYY	

### Appendix 3

Component Name	Toxic and hazardous substances or elements					
	Plumbum	Mercury	Cadmium	Hexavalent Chromium	Polybrominated Biphenyls	Polybrominated Diphenyl Ethers
	Pb	Hg	Cd	Cr6+	PBB	PBDE
PCB	○	○	○	○	○	○
Rubber Parts	○	○	○	○	○	○
Cable	○	○	○	○	○	○
Shell	○	○	○	○	○	○
Sheet Metal Parts	○	○	○	○	○	○
<p>○: Indicates that the content of the toxic and hazardous substance in all homogeneous materials of the part is below the limit requirement stipulated in SJ/T-11363-2006</p> <p>×: Indicates that the content of the toxic and hazardous substance in at least one homogeneous material of the part exceeds the limit requirement stipulated in SJ/T11363-2006</p>						
<p>Note on the Environmental protection period: The environmental protection period of this product (marked on the product body) refers to the period from the date of production when the toxic and harmful substances or elements contained in this product will not cause serious impact on the environment, human life and property under normal conditions of use and in compliance with the safety precautions of this product.</p>						
<p>Scope of application: Integrated AC charger.</p>						